

# BB-TC-1A-EN-CL Tubing Hanger with BB-A5P-CL Adapter Flange for Non-Continuous Control Lines

## Product Information

- Medium to Heavy Capacity Hanger
- Easy Installation
- Economical Design
- Lockscrew Energized Annular Seal
- Single or Double DHCV Line
- Lift Threads for Lowering
- No Special Tools Required
- Threaded "H" Type Back Pressure Valve
- Adapter Connections in Many Sizes
- Separate Test Fittings

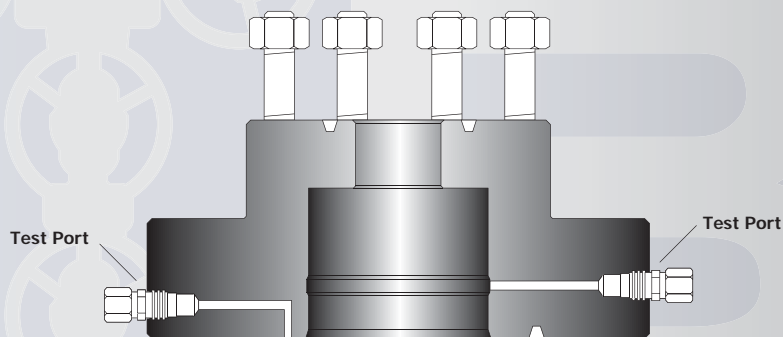

**BB-AP5-CL  
Adapter Flange**

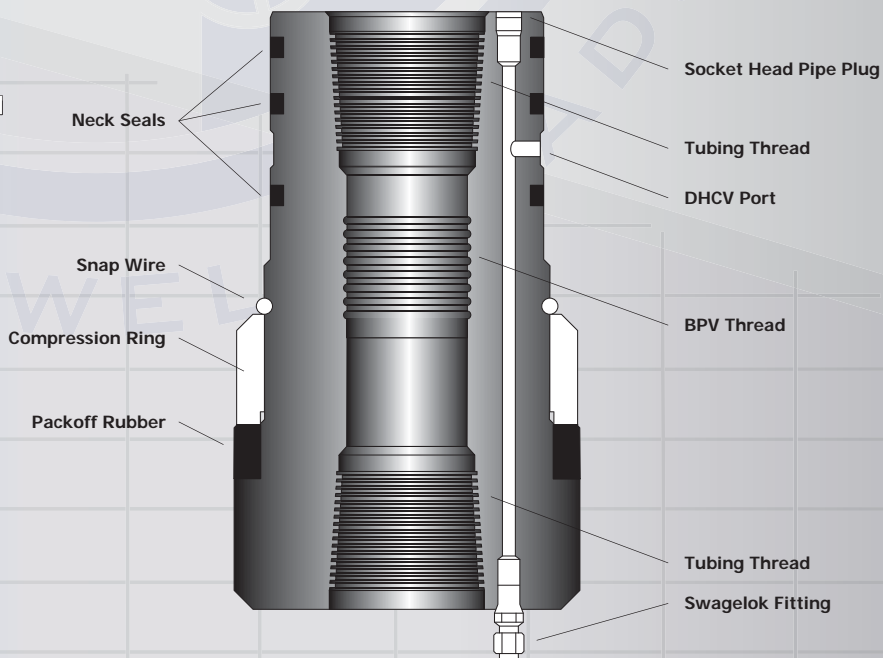
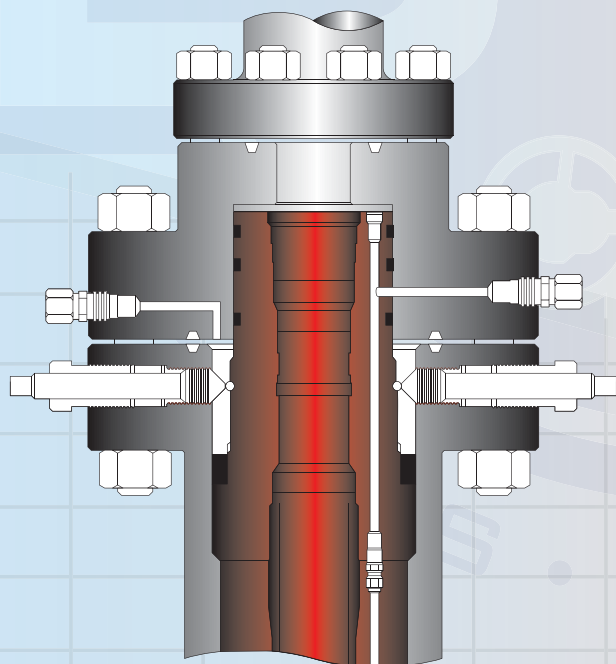

**BB-TC-1A-EN-CL  
Tubing Hanger**