

# BB-21 and BB-21-P Manually Energized Seal Slip-Type Casing Hangers

## Product Information

- BB-21 is a Split, Segmented, Wraparound Casing Hanger
- Serves as Primary Seal when Spool is Installed
- Protects the BB-21 Slip from Test Pressure
- Designed for use over Mudline Suspension System
- Energized with Compression or Lockscrews
- Capable of Supporting 50% of Casing Joint Strength
- BB-21-P cannot be used with BB-22-BP or BB-29-BP
- Will Accommodate the Full API Tolerance Range for Casing O.D.
- Special Casing Hangers are Available

| Casing Hanger Availability |                   |         |         |     |
|----------------------------|-------------------|---------|---------|-----|
| Casing Size                | Nominal Bowl Size |         |         |     |
|                            | 11"               | 13-5/8" | 16-3/4" | 20" |
| 4-1/2"                     | 1,3               |         |         |     |
| 5"                         | 1,2,3             |         |         |     |
| 5-1/2"                     | 1,2,3,4           | 3       |         |     |
| 6-5/8"                     | 1,2,3,4           |         |         |     |
| 7"                         | 1,2,3,4           | 1,2,3,4 |         |     |
| 7-5/8"                     | 2,3,4             | 1,2,3,4 |         |     |
| 8-5/8"                     |                   | 1,2,3,4 |         |     |
| 9-5/8"                     |                   | 1,2,3,4 | 2,3,4   |     |
| 10-3/4"                    |                   | 2,3     | 2,3,4   | 2   |
| 11-3/4"                    |                   |         | 2,3,4   | 2   |
| 13-3/8"                    |                   |         | 2,3,4   | 2,3 |
| 16"                        |                   |         |         | 2,3 |

BB-21=1, BB-21-P=2, BB-22=3, BB-29=4

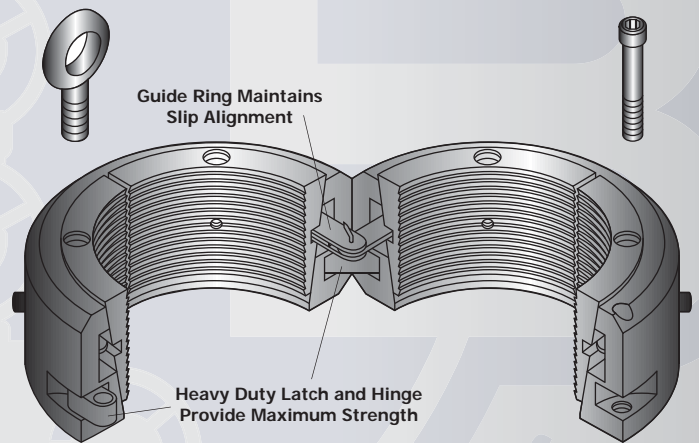

**BB-21  
Casing Hanger**

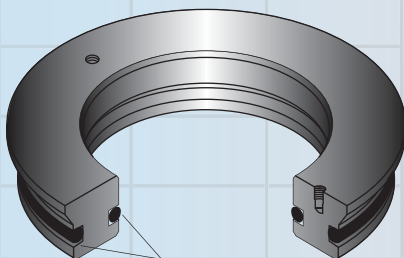

Self Energized  
O-Ring Protects  
Ring Gasket and  
Slips from Annular Pressure

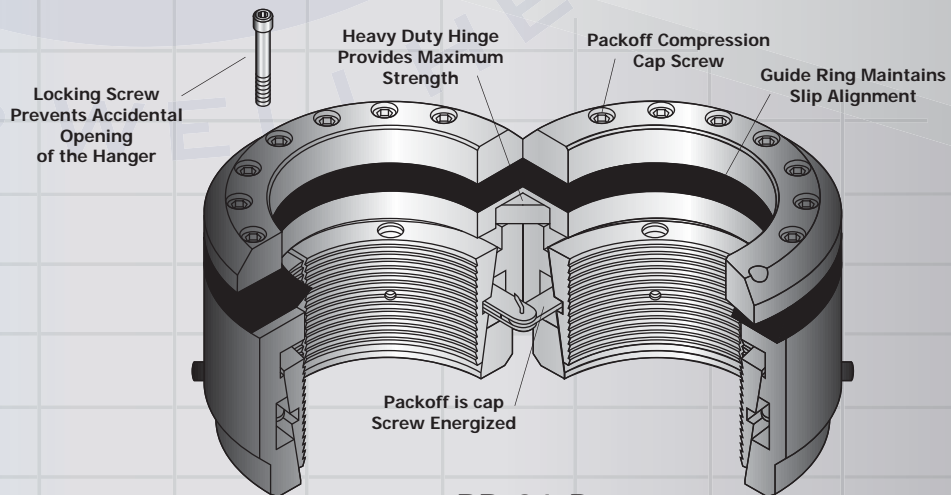

**BB-21-P  
Casing Hanger**